

GPS Lightning Protection

Introduction

Facilities with connections to the outside may suffer damage due to lightning. The electronic components are extremely sensitive to high voltage and to major energy sources such as lightning, which is the most common danger as well as being completely unforeseeable.

Characteristics of Electromagnetic Phenomena

SOURCE	Nb./YEAR	ELECTRICAL ENERGY	FREQUENCY	RISK FACTOR
LIGHTNING	10 to 100	High	10 kHz to 1 MHz	Geographical Zone
ELECTROSTATIC DISCHARGE	10 to 1000	Low	10 MHz to 500 Mhz	Product Handling
NUCLEAR IMPULSE	0	Medium	1 MHz to 10 MHz	Political

To protect people and equipment from lightning, it is essential to ensure that all wire connections to building exteriors include the appropriate form of protection. It only takes one unprotected connection to admit the lightning, which then, causes damage by induction, to the other cables.

GPS Lightning Protection

GPS coaxial lightning protection consists of a gas gap.

At rest, the gas forms a high resistance insulator. In the event of a voltage surge, the gas immediately and automatically creates a short circuit and the high-voltage current is discharged to the ground. A residual voltage of about 90V remains instead of an inadmissible potential difference.

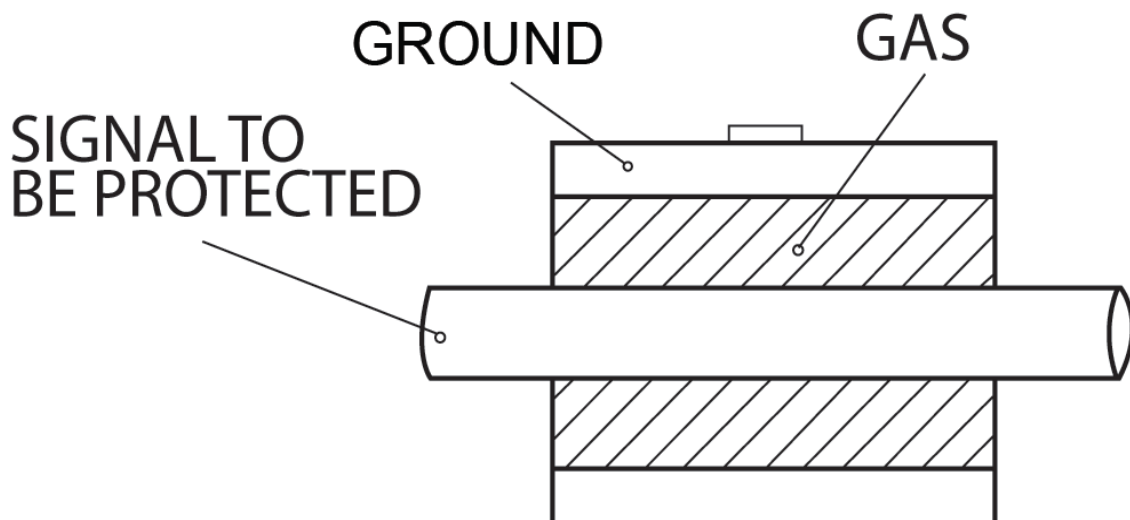

Once the energy from the lightning has been shunted to the ground, the gas returns to its initial state of rest as an insulator. GPS lightning protection, which is specifically designed for 1500 MHz, is totally user-transparent.

continued on the back 



GPS Lightning Protection

Installation of Lightning Protection

GPS Lightning Protection is efficient:

- Installed at the point where the coaxial cable enters the building.
- Ground connection for discharging the energy from the lightning.

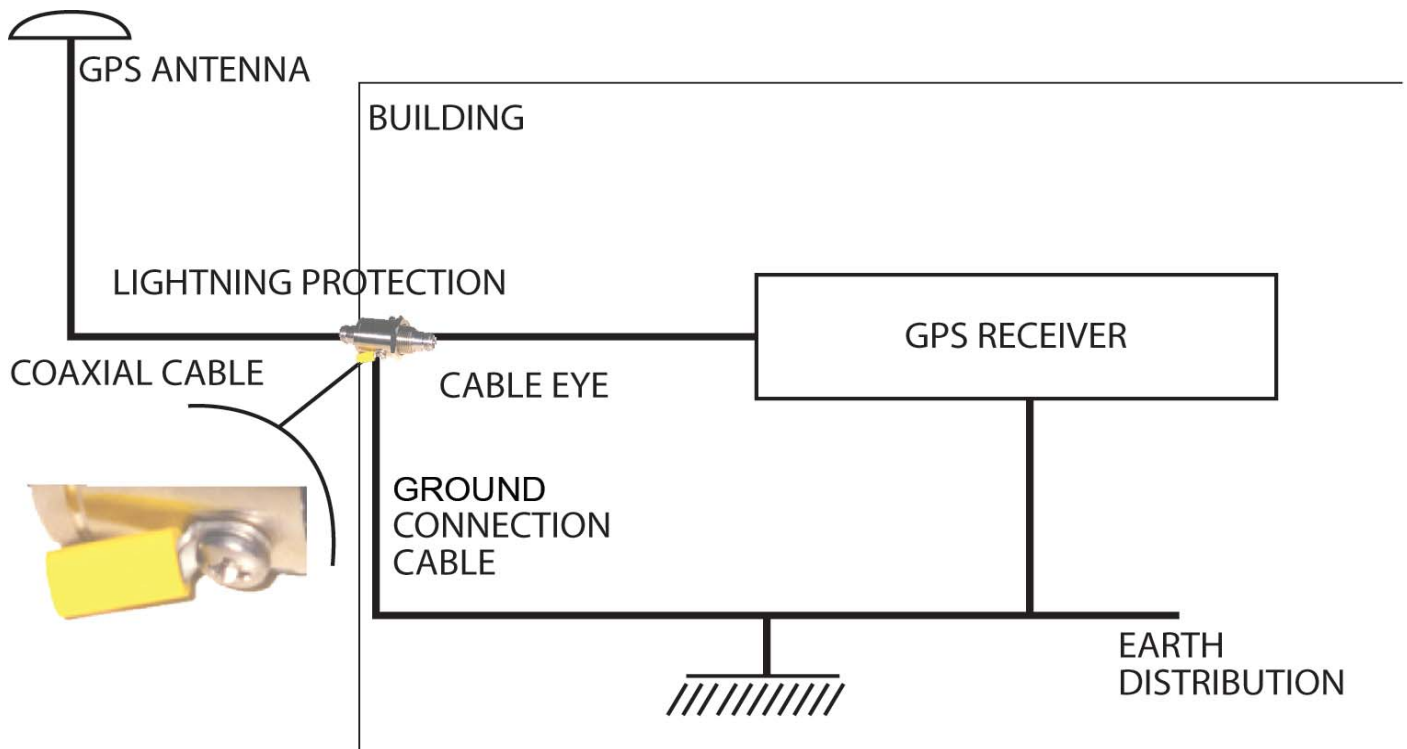

The lightning ground connection must have a low impedance value. Use a section greater than 3mm² and the shortest possible length of cable between the protection and the building ground connection.

Use the same ground for all the protections so as to prevent any flow of current between the grounds of the different installations.

Installed as above, GPS lightning protection reduces the probability of a receiver failure due to lightning. There will be a temporary loss of GPS reception during this event.