

Full Redundant GPS Clock with Distribution for DVB-T

Introduction

Terrestrial Digital Video Broadcast (DVB-T) features require synchronization. A cost effective solution is to provide synchronization from a clock disciplined by GPS signals.

Whereas basic needs are met by single GPS Clocks, requirements such as high number of time and frequency outputs for large base station or guaranteed service continuity are not fulfilled. Typical examples are GPS antenna failure with long "Mean Time To Repair" due to roof accessibility or possible clock equipment failure.

GPS Clocks

GPS Clocks provide both a frequency reference and an absolute time reference slaved on GPS signals referenced to Coordinated Universal Time (UTC). Due to the global availability of the GPS signal, a GPS Clock is the most cost effective solution to fulfill the DVB-T synchronization requirements that are disseminated on numerous locations.

Spectracom, using its expertise in time and frequency synchronization systems, has developed a full range of GPS Clocks that are specifically designed to fulfill digital broadcast requirements. These modular rack mounted units (Epsilon Clock™) deliver a wide range of outputs required for a multi-transmitter site.

Synchronization output signals are:

- 4 x 10 MHz frequency references
- 1 pulse per second
- Time of Day (ToD)



Epsilon Clock 2S

An internal high performance oscillator (Oven Controlled Quartz Oscillator) slaved to the GPS input source brings a high level of performance to Epsilon Clocks: high accuracies with excellent phase noise. Optimized slaving algorithm combined with excellent short term stability of the oscillator mitigates the effects of GPS selective availability. Furthermore, "Time Receiver Autonomous Integrity Monitoring" (T-RAIM) is achieved to discard faulty GPS satellites and then ensure time integrity.

In case of GPS input reference disruption, the high stability oscillator along with microprocessor control allows an efficient Holdover Mode where time and frequency accuracies are maintained.

Spectracom offers the right products with a complete range of associated customer services (installation, training, support, after-sales, and consultancy) which guarantees the required quality of service for the DVB-T network.

continued on the back →



Full Redundant GPS Clock with Distribution for DVB-T

DVB-T Feature and Synchronization Requirements

The Terrestrial Digital Video Broadcast (DVB-T), specified in the ETSI standard EN 300 744, is designed to allow optimum use of available frequency spectrum while offering new services such as multiplex of programs and portable video reception.

The DVB core system consists of generating data "containers," which carry flexible combinations of MPEG-2 video, audio, and other data with encoded protection schemes. The key specific feature is the use of a multi-carrier modulation system (COFDM) to overcome adjacent channel interference and reflections of the same signal (ghosting). This COFDM process allows the construction of Single Frequency Networks (SFN), where all the transmitters use the same frequencies, which permits "gap-filling" for optimizing coverage in difficult spots.

These features have convinced many countries to adopt the DVB-T standard, including 15 members of the European Union, Australia and New Zealand. Numerous DVB-T broadcast services are now operational in Europe.

The RF transmission through SFN requires an overall time and frequency synchronization. Indeed, for each instant of time, every transmitter must broadcast the same digital data at the same exact frequency. This implies extensive use of clock equipment in all transmission stations to compensate propagation delay within internal distribution network and to synchronize COFDM encoder and modulator along with up converter for RF generation.

More technical presentation of DVB-T features with synchronization needs is described in Application Note: DVB-T Synchronization Needs.

Time and Frequency Amplifier System

When multiple time and frequency signals are required on separate locations within a base or transmission station, the smart solution is to use the compact and reliable Epsilon Amplifier System.

The Epsilon Amplifier System receives a set of time and frequency signals from an Epsilon Clock then buffers and distributes up to 16 times the frequency reference, 16 times the 1 PPS signal and 4 times the ToD message. The careful amplification design of the Epsilon Amplifier System preserves the excellent phase noise performances of the Epsilon Clock oscillators and insures input phase characteristics of 1 PPS signals. The frequency amplifiers are optimized for the 1 MHz to 20 MHz bandwidth.

The Epsilon Amplifier System is a standard 19" rack mounted unit and exists in two versions:

- the 8 output channel version in 1U high package (outputs: 8 frequencies, 8 x 1PPS, 1 ToD, 1 alarm status)
- the 16 output channel version in 2U high package (outputs: 16 frequencies, 16 x 1PPS, 4 ToD, 1 alarm status)

The Epsilon Amplifier System can be configured to activate the monitoring of input signals, by setting the associated DIP switches on rear panel. Signal monitoring of the following signals can be activated or excluded:

- Frequency reference input
- 1 PPS input
- ToD input
- Alarm input from GPS clock

LED indicators on front panel highlight input and output signal status:

- Green LEDs: AL, F, 1 PPS and ToD indicates correct signals coming from GPS clock
- Red LED alarm indicates absence or failure of one or more input or output signals which monitoring has been activated

This equipment can be powered both by Mains voltage (110-220 Vac) and DC voltage (24 V).

continued on the next page →



Full Redundant GPS Clock with Distribution for DVB-T

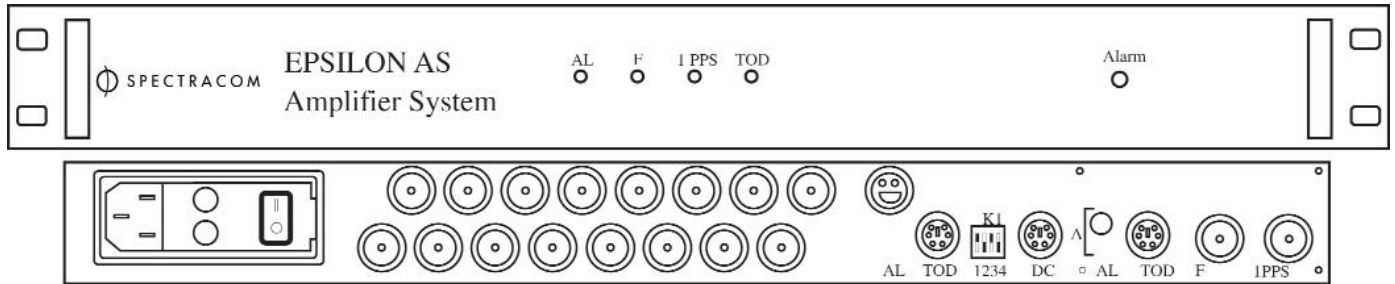

Front and rear views of Epsilon Amplifier System - 1U package

High Availability Redundant Clock System

The mass market applications of DVB-T with large subscriber audience requires high level of service and reliable synchronization equipment.

For this, the Epsilon Switch & Amplifier System provides a cost effective way to build a redundant clock system with high operational availability through simple use of standard and low cost Epsilon Clock series.

The Epsilon Switch & Amplifier System receives two sets of time and frequency signals from two Epsilon Clocks, then input signals are monitored and source selection/switching is automatically achieved when signal failure is detected. Signals from the selected source are buffered and distributed with the same possibilities as the Epsilon Amplifier System described previously: distribution of up to 16 times the frequency reference, 16 times the 1 PPS signal and 4 times the TOD message with excellent phase noise performances (1 MHz to 20 MHz bandwidth) and preservation of input phase characteristics of 1 PPS signals.

Functional synopsis is (8 output channel version):

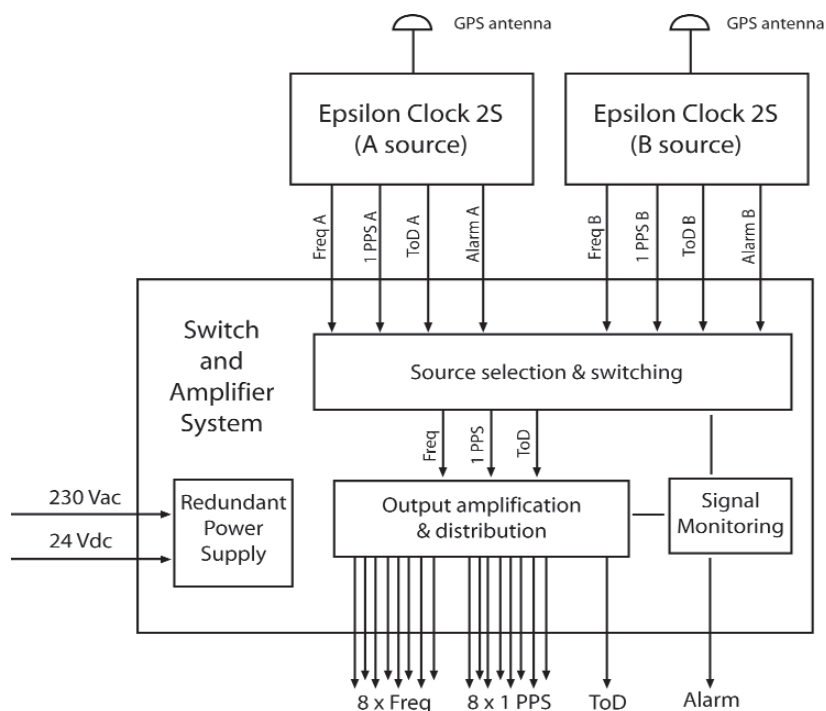

continued on the back





Full Redundant GPS Clock with Distribution for DVB-T

The decision and switching circuits are robust with no CPU or software process in order to avoid any bugs or general breakdown which can jeopardize this essential function.

On option, the Epsilon SAS can ensure smooth phase shifting when switching frequencies from one source to the other with no phase jump on 1 PPS signals.

The Epsilon SAS can be user configured to monitor one to four signal types from each source (Freq., 1 PPS, ToD, source alarm), by setting the associated DIP switches on rear panel: absence of signal which monitoring is not activated is not seen as a default.

When preventive maintenance of one source is carried out, the source selection can be forced by the user via the 3 position switch located on the front panel. The nominal position is "auto," i.e. automatic selection deduced from signal presence and monitoring; "A" or "B" position force the selection of the associated source.

The Epsilon Switch and Amplifier System is a standard 19" rack mounted unit and exists in two versions:

- the 8 output channel version in 1U high package (outputs: 8 frequencies, 8 x 1 PPS, 1 ToD, 1 alarm status)
- the 16 output channel version in 2U high package (outputs: 16 frequencies, 16 x 1 PPS, 4 ToD, 1 alarm status)

LEDs indicators on front panel highlight input & output signal status:

- Green LEDs (AL, F, 1 PPS, and ToD) indicate correct signals coming from each GPS clock (sources A & B)
- Red LED (Alarm) indicates absence or failure of input or output signal(s) which monitoring has been activated
- Yellow LEDs indicate the selected source (A or B). When automatic selection is activated, two LEDs are on: "Auto" and the selected source.

This equipment can be powered both by Mains voltage (230 Vac) and DC voltage (24 V).

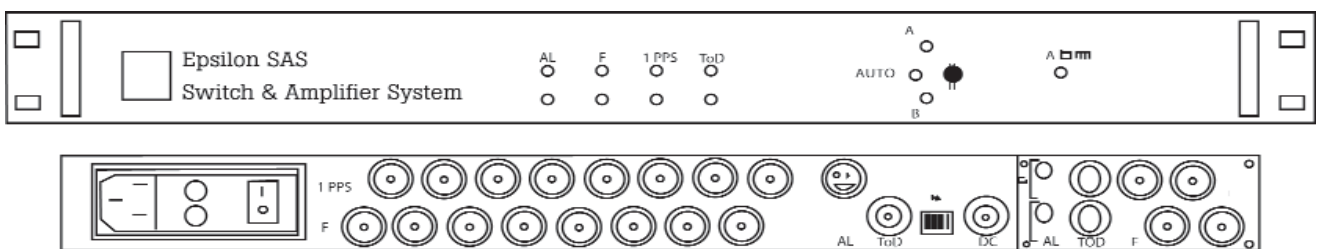

Front and rear views of Epsilon Switch & Amplifier System - 1U package